



# FES MOTOR MANUAL

Version 1.6

Type: **FES-LAK-C100**



LZ design d.o.o., • Brod 3D, 1370 Logatec, Slovenia • tel +386 59 948 898  
[info@lzdesign.si](mailto:info@lzdesign.si) • [www.front-electric-sustainer.com](http://www.front-electric-sustainer.com)

SPORTINE AVIACIJA ir Ko • Pociunai, LT-59327 Prienai, Lithuania • tel: +370 319 60567  
[info@lak.lt](mailto:info@lak.lt) • [www.lak.lt](http://www.lak.lt)

**Table of Content**

1. Important notices .....	3
1.1 Limited Warranty .....	3
2. General.....	4
3. Model designation .....	4
4. Technical data and limitations of motor .....	5
5. Drawing of motor .....	7
6. Maintenance .....	8
7. Removal of motor.....	9
8. Installation of motor .....	9
9. Repair and service.....	10
10. Revision history .....	10

## 1. Important notices

Please read this manual thoroughly. It contains important information about your system, having a vital importance to the flight safety.

Information in this document is subject to change without notice. LZ design reserves the right to change or improve their products and to make changes in the content of this material without obligation to notify any person or organization of such changes or improvements.

The following definitions apply to warnings, cautions and notes used in this manual.



**Warning:** *Means that the non-observation of the corresponding procedure leads to an immediate or important degradation of the flight safety.*



**Caution:** *Means that the non-observation of the corresponding procedure leads to a minor or to a long-term degradation of the flight safety.*



**Note:** *Draws the attention to any special item not directly related to safety but which is important or unusual.*

### 1.1 Limited Warranty

This motor is warranted to be free from defects in materials or workmanship for two years from the date of purchase. Within this period, LZ design will, at its sole option, repair or replace any components that fail in normal use. Such repairs or replacement will be made at no charge to the customer for parts and labour, the customer shall be responsible for any transportation cost. This warranty does not cover failures due to abuse, misuse, accident, or unauthorized alterations or repairs.

THE WARRANTIES AND REMEDIES CONTAINED HEREIN ARE EXCLUSIVE AND IN LIEU OF ALL OTHER WARRANTIES EXPRESSED OR IMPLIED OR STATUTORY, INCLUDING ANY LIABILITY ARISING UNDER ANY WARRANTY OF MERCHANTABILITY OR FITNESS FOR A PARTICULAR PURPOSE, STATUTORY OR OTHERWISE. THIS WARRANTY GIVES YOU SPECIFIC LEGAL RIGHTS, WHICH MAY VARY FROM STATE TO STATE.

IN NO EVENT SHALL LZ DESIGN BE LIABLE FOR ANY INCIDENTAL, SPECIAL, INDIRECT OR CONSEQUENTIAL DAMAGES, WHETHER RESULTING FROM THE USE, MISUSE, OR INABILITY TO USE THIS PRODUCT OR FROM DEFECTS IN THE PRODUCT. Some states do not allow the exclusion of incidental or consequential damages, so the above limitations may not apply to you. LZ design retains the exclusive right to repair or replace the unit or software, or to offer a full refund of the purchase price, at its sole discretion. SUCH REMEDY SHALL BE YOUR SOLE AND EXCLUSIVE REMEDY FOR ANY BREACH OF WARRANTY.

To obtain warranty service, contact your local LZ design dealer or contact LZ design directly.

## 2. General

Congratulations on your purchase. This is a high-end product of brushless synchronous permanent magnet motor with electronically controlled commutation system 3 phase, which will keep its capability for a long time if treated the right way.

The drive was developed and very elaborately tested by Ing. Matija Žnidaršič and Ing. Luka Žnidaršič.

The development objective was to build suitable motor for FES application which must be light and small enough to fit into sailplane front part of fuselage, but very powerful providing specific performance at highest efficiency.

This motor allows a gearless drive without the usually essential gear unit which cause power losses, additional weight, complexity, and maintenances. Because of the little internal resistance of the motor, very good performances are achieved in a wide range and at an excellent efficiency.

Though many intensive tests had already been made and though the parts were produced by modern CNC machines, the drive is still not a real series product. Some manufacturing processes like windings are made by hand, what makes every drive of the first series unique.

## 3. Model designation

Motor model designation is the following:

FES-LAK-C100  
(1) (2) (3)

where:

- (1) motor application
- (2) designed for sailplane model; LAK17C FES
- (3) approximate motor length in mm

Motor serial-number is identified as number which follows model designation

sn: XXX

Motor identification numbers are engraved into rear Aluminum plate of motor.

#### 4. Technical data and limitations of motor

Motor construction is outrunner BLDC brushless synchronous permanent magnet motor with electronically controlled commutation system 3 phase. Rotor position is determined by 3 hall sensors and additional 4th hall sensor for automatic propeller positioning.

This motor can work only in combination with suitable electronic Controller which transform DC current from Battery packs to 3 phase current which supply motor. We use controller type which needs hall position sensors in motor, but this motor can work also with some sensorless controllers.

Electrical motor type FES-LAK-C100 power ratings at 133V on motor controller and loaded with FES-LAK-P11-100 propeller:

Maximum torque	75 Nm
Maximum current	280A
Maximum Voltage	133V
Rpm non loaded	45 rpm/V
Rpm non loaded (at 133V DC on Controller)	6000 rpm
Non loaded motor current (at 6000 rpm)	18-20 A
Rpm loaded with FES-LAK-P11-100 propeller (1m diameter)	5300 rpm
Battery current loaded (5300 rpm, 133V) with FES-LAK-P11-100	up to 280 A
Rotor rink diameter	177mm
Motor length	100mm
Motor weight cca.	7,3 kg
Motor efficiency	82-95 %
Maximum allowed temperature	90 °C
Minimum allowed starting temperature	-20 °C

Power load on motor P (kW) is dependable of propeller diameter, geometry, pitch, and its rotation speed n (RPM-rotation per minute). However, rotation speed of motor is than dependable on available Voltage on controller. Higher Voltage, higher rpm!

With small propeller (1m) and high Rpm (5300 RPM) at 120V motor is loaded with 250A. **This motor is mostly suitable for smaller, and faster rotating propellers!**

Maximum continuous current is mostly dependable of how good cooling can be provided to motor.

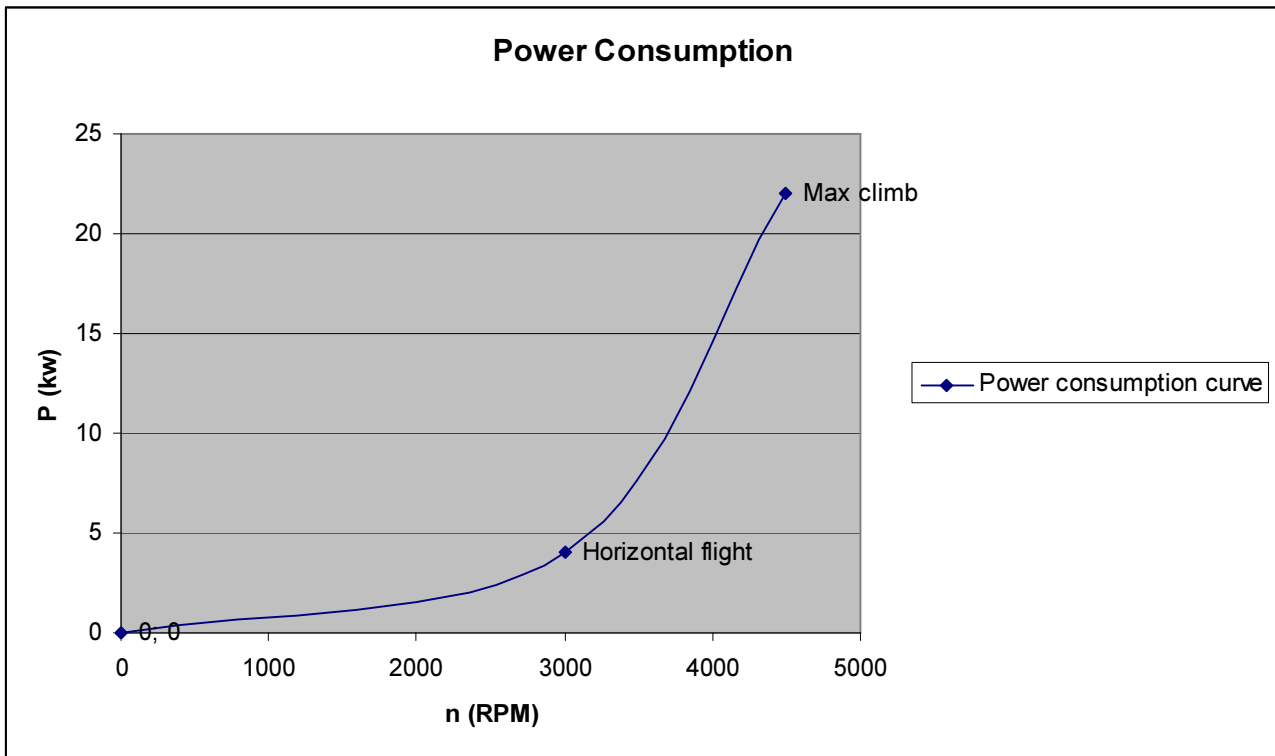

Rpm versus Power at 116V

### 5. Drawing of motor

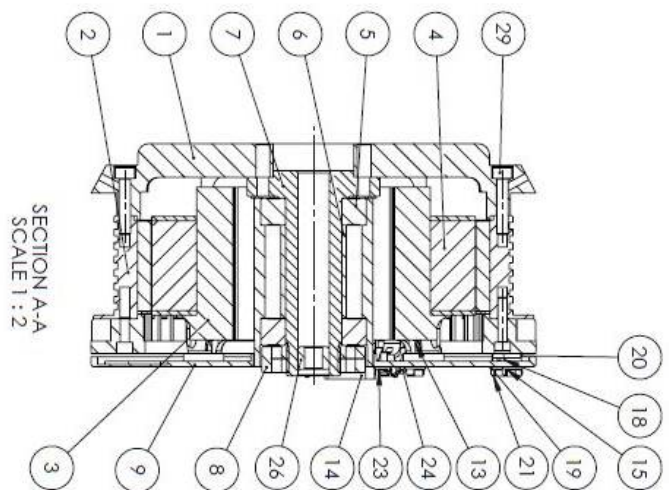
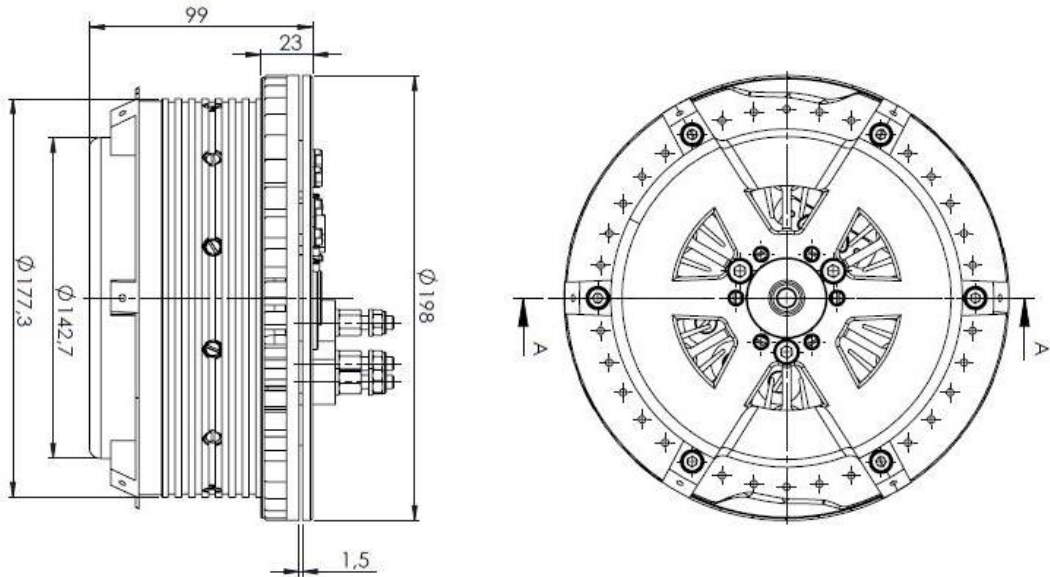

SECTION A-A  
SCALE 1 : 2

ITEM NO.	PART NUMBER	QTY.
1	Torsional plate for LAK v3.0	1
2	Rotor ring	1
3	Stator block	1
4	Stator plates	1
5	Bearing NSK 6005 ZZ	2
6	Bearing spacer	1
7	Shaft	1
8	Rear cover plate v2.1	1
9	Isolation spacer upper	3
10	Isolation spacer lower	3
11	Centrifugal ventilator v2.0	1
12	Hall sensors holder	1
13	DB1.5_F	1
14	Safety spacer 3 v1.0	1
15	contact terminal	3
16	magnet 5x5mm	2
17	4th hall plate without thread	1
18	M4 spacer inox	4
19	4th hall plate with M4 thread	1
20	Hexagon bolt M4x8 inox	4
21	M6 spacer inox	6
22	M3 vialk lecasta glava	2
23	small plate with locking spring	2
24	M6 NYLOC	3
25	Brass bushing for shaft	1
26	Hexagon Nut ISO - 4034 - M6 - N	3
27	ISO 1207 - M4 x 6 --- 6N	12
28	ISO 4762 M5 x 20 --- 20N	6
29	ISO 4762 M4 x 20 --- 20N	6
30	ISO 4762 M4 x 6 --- 6N	2
31	ISO 4762 M5 x 20 --- 20N	3
32	ISO 4762 M5 x 20 --- 20N	3

Scale:	1:2	Material:		Dimension:		Weight:		Comments:	Black anodized
Title: FES LAK M100 cross section									
Date:	10.10.13	Name:	Luka Zrindarsic	Signature:		Drawing filename:	FES_LAK_M100_cross_section		
Drawn:		Checked:							

## 6. Maintenance

The motor does not need any maintenance. Opening or disassembling of the motor would cause a forfeit of warranty claims! It could be also very dangerous, due to very strong magnets on rotor!

Though, it must be considered that no foreign objects at all can enter the interior of the drive.

Further, it is necessary to protect the motor from humidity, dirt, paint, glues etc. If this is ignored, a proper functionality of the motor cannot be guaranteed, and irreparable damages are possible. In case of damage, ship the drive back to the manufacturer for repairs. Unintended handling leads to secondary damages.

Keep magnetic memory cards or electronic devices out of the rotor's close-up range, because the alternating magnetic field can cause a delete of data. Be careful with medical devices (e.g. pacemakers) which might be sensitive to alternating magnetic fields.

The small gap between the stator and the magnets of the rotor function-bound has a thickness of only a few tenth millimeters. Here, the danger of foreign objects accumulating in this gap exists but can be heard by scratching-sounds. In this case spinner should be removed and the motor should be blown-out with compressed air. Do not at all simply keep on using the drive. Be especially aware of cuttings which can almost irremovably stick to the magnets. In this case, the only thing that helps is a disassembly of the drive by the manufacturer.



## 7. Removal of motor



**Note:** Removal of motor from sailplane is only allowed in case of **written permission** from manufacturer otherwise warranty is not valid anymore!



**Warning:** It is not allowed to fly with removed motor from the sailplane, as C.G. position change significantly!

**To remove the motor from the glider** (complete with spinner and propeller)

1. Open ventilation (fully forward position)
2. Remove round composite cover from centre of front motor mounting rib (from cockpit side)
3. Unlock springs which hold DB15 cable connector and then carefully unplug connector from motor rear wall.
4. Unscrew 3 self-locking nuts from rear motor wall and disconnect 3 power cables. Before disconnection is recommended to mark them as A, B, C, and draw their position against each other on list of paper.
5. Unsecure six M8 bolts and unscrew them out. One of M8 bolts which is below powers wires have lower head. Hold motor assembly, and carefully take it out of fuselage.

## 8. Installation of motor

**To install motor back to the glider**, follow the reverse order.

Take care about additional steps:

1. Open ventilation fully-lever pushed forward.
2. It is recommended to use new bolt securing plates to secure M8 motor fixation bolts.
3. Make sure that power cables are connected in the same order as before, otherwise motor will not work. Use only new M6 self-locking nuts. **Tightening moment should be 5Nm.** Make sure that there is no contact between cable shoes, motor mounting wall, or with M8 bolts which holds the motor. One of the cables is a bit closer to M8 bolt which hold the motor. On this location must be used special M8 bolt with lower head.
4. Carefully plug in signal wires connector into motor rear wall connector. Lock springs which hold connector in place.

After motor is reinstalled, check the following:

- Spinner is in the centre of fuselage
- Gap between spinner and fuselage is 0,5-1mm
- All bolted connections assembled correctly and secured properly
- Start the motor on a ground and run it for a few seconds to check:
- Motor rotating direction, smooth run of motor
- Braking of propeller works OK
- FCU instrument is functioning properly

**9. Repair and service**

In case of a fault or damage(s), contact manufacturer.

**10. Revision history**

June 2022	Initial release of manual v1.6
-----------	--------------------------------