



# FES MOTOR MANUAL

Version 1.21

Type: **FES-LS8-M100**



LZ design d.o.o., • Brod 3D, 1370 Logatec, Slovenia • tel +386 59 948 898  
[info@lzdesign.si](mailto:info@lzdesign.si) • [front-electric-sustainer.com](http://front-electric-sustainer.com)

**Table of Content**

1. Important notices .....	3
1.1 Limited Warranty .....	3
2. General.....	4
3. Model designation .....	4
4. Technical data and limitations of motor .....	5
5. Drawing of motor .....	7
6. Maintenance .....	8
7. Removal of motor.....	9
8. Installation of motor .....	11
9. Repair and service.....	12
10. Revision history .....	12

## **1. Important notices**

Please read this manual thoroughly. It contains important information about your system, having a vital importance to the flight safety.

Information in this document is subject to change without notice. LZ design reserves the right to change or improve their products and to make changes in the content of this material without obligation to notify any person or organization of such changes or improvements.

### **1.1 Limited Warranty**

This motor is warranted to be free from defects in materials or workmanship for two years from the date of purchase. Within this period, LZ design will, at its sole option, repair or replace any components that fail in normal use. Such repairs or replacement will be made at no charge to the customer for parts and labour, the customer shall be responsible for any transportation cost. This warranty does not cover failures due to abuse, misuse, accident, or unauthorized alterations or repairs.

THE WARRANTIES AND REMEDIES CONTAINED HEREIN ARE EXCLUSIVE AND IN LIEU OF ALL OTHER WARRANTIES EXPRESSED OR IMPLIED OR STATUTORY, INCLUDING ANY LIABILITY ARISING UNDER ANY WARRANTY OF MERCHANTABILITY OR FITNESS FOR A PARTICULAR PURPOSE, STATUTORY OR OTHERWISE. THIS WARRANTY GIVES YOU SPECIFIC LEGAL RIGHTS, WHICH MAY VARY FROM STATE TO STATE. IN NO EVENT SHALL LZ DESIGN BE LIABLE FOR ANY INCIDENTAL, SPECIAL, INDIRECT OR CONSEQUENTIAL DAMAGES, WHETHER RESULTING FROM THE USE, MISUSE, OR INABILITY TO USE THIS PRODUCT OR FROM DEFECTS IN THE PRODUCT.

Some states do not allow the exclusion of incidental or consequential damages, so the above limitations may not apply to you. LZ design retains the exclusive right to repair or replace the unit or software, or to offer a full refund of the purchase price, at its sole discretion. SUCH REMEDY SHALL BE YOUR SOLE AND EXCLUSIVE REMEDY FOR ANY BREACH OF WARRANTY.

To obtain warranty service, contact your local LZ design dealer or contact LZ design directly.

## 2. General

Congratulations on your purchase. This is a high-end product of brushless synchronous permanent magnet motor with electronically controlled commutation system 3 phase, which will keep its capability for a long time if treated the right way.

The drive was developed and very elaborately tested by Ing. Matija Žnidaršič and Ing. Luka Žnidaršič.

The development objective was to build suitable motor for FES application which must be light and small enough to fit into sailplane front part of fuselage, but very powerful providing specific performance at highest efficiency.

This motor allows a gearless drive without the usually essential gear unit which cause power losses, additional weight, complexity and maintenances.

Because of the little internal resistance of the motor, very good performances are achieved in a wide range and at an excellent efficiency.

Though many intensive tests had already been made and though the parts were produced by modern CNC machines, the drive is still not a real series product. Some manufacturing processes like windings are made by hand, what makes every drive of the first series unique.

## 3. Model designation

Motor model designation is the following:

FES-LS8-M100  
(1) (2) (3)

where:

- (1) motor application
- (2) designed for sailplane model
- (3) approximate motor length in mm

Motor serial-number is identified as number which follows model designation

sn: XXX

Motor identification numbers are engraved into rear Aluminium plate of motor.

#### 4. Technical data and limitations of motor

Motor construction is outrunner BLDC brushless synchronous permanent magnet motor with electronically controlled commutation system 3 phase. Rotor position is determined by 3 hall sensors and additional 4th hall sensor for automatic propeller positioning.

This motor can work only in combination with suitable electronic Controller which transform DC current from Battery packs to 3 phase current which supply motor. We use controller type which needs hall position sensors in motor, but this motor can work also with some sensorless controllers.

Electrical motor type FES-LS8-M100 power ratings at 116V on motor controller and loaded with FES-LS8-P1-102 propeller:

Maximum torque	75 Nm
Maximum current	200A
Maximum Voltage	116V
Rpm non loaded	45 rpm/V
Rpm non loaded (at 116V DC on Controller)	5300 rpm
Non loaded motor current (at 5300 rpm)	16-18 A
Rpm loaded with FES-LS8-P1-100 propeller (1m diameter)	4500 rpm
Battery current loaded (4500 rpm, 116V) with FES-LS8-P1-102	Up to 200 A
Rotor rink diameter	182mm
Motor length	100mm
Motor weight cca.	8,0 kg
Motor efficiency	82-95 %
Maximum allowed temperature	90 °C
Minimum allowed starting temperature	-20 °C

Power load on motor P (kW) is dependable of propeller diameter, geometry, pitch and its rotation speed n (RPM-rotation per minute). However, rotation speed of motor is than dependable on available Voltage on controller. Higher Voltage, higher rpm!

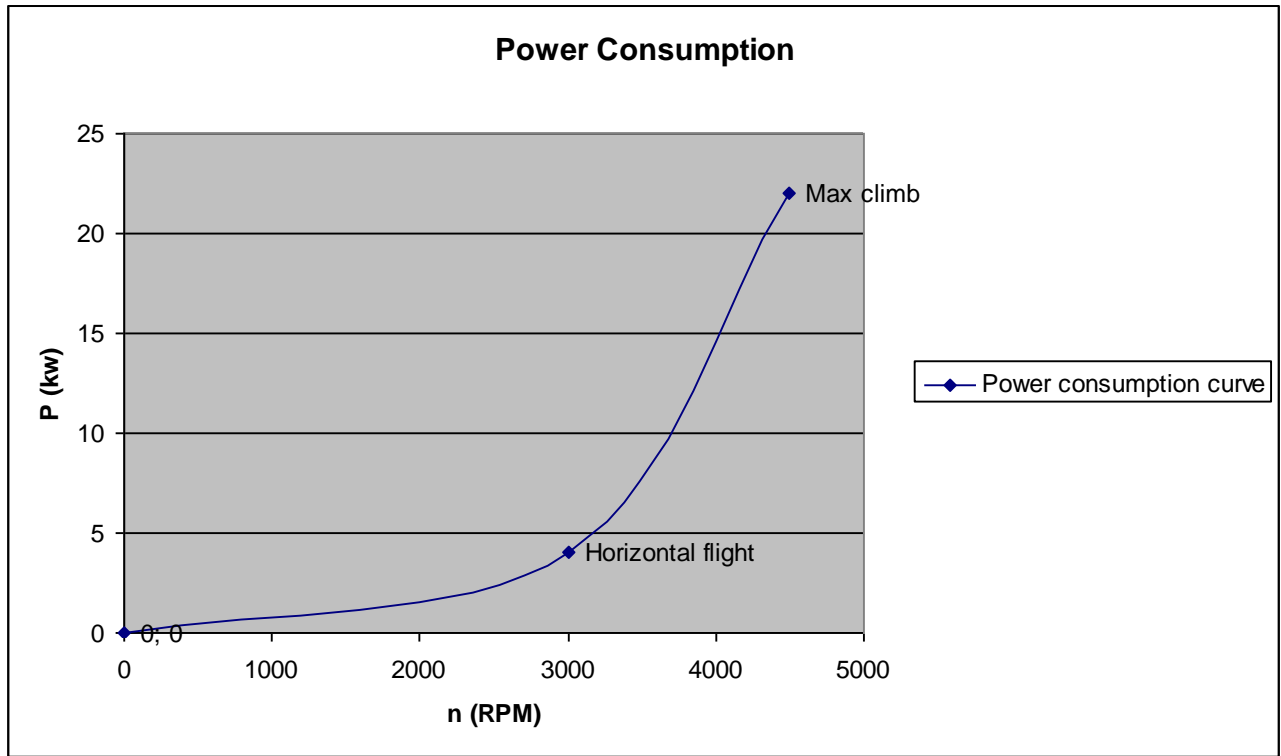

Rpm versus Power

5. Drawing of motor

The drawing includes a front view of the motor, a side view, and a detailed section A-A. The section A-A shows the internal components of the motor, including the stator, rotor, and shaft assembly, with numbered callouts from 1 to 11. The scale for section A-A is 1:2.

ITEM NO.	PART NUMBER	QTY.
1	Torsional plate LS8 v1.0	1
2	Rotor ring	1
3	Stator block	1
4	Stator plates	1
5	Bearing NSK 6005 ZZ	2
6	Bearing spacer	1
7	Shaft	1
8	Shaft safety nut	1
9	Rear cover plate v2.3	1
10	Isolation spacer upper	3
11	Centrifugal ventilator v2.0	1

Scale:	1:2	Material:		Dimensions:		Weight:		Comments:	
<p><b>DESIGN</b> Title: FES-LS8-M100</p>									
Drawn:	19.03.19	Name:	Luka Znidarsic	Signature:		Drawing Name: FES-LS8-M100			
Checked:									

## 6. Maintenance

**The motor does not need any maintenance. Opening or disassembling of the motor would cause a forfeit of warranty claims! It could be also very dangerous, due to very strong magnets on rotor!**

Though, it has to be considered that no foreign objects at all can enter the interior of the drive.

Further, it is necessary to protect the motor from humidity, dirt, paint, glues etc. If this is ignored, a proper functionality of the motor cannot be guaranteed, and irreparable damages are possible. In case of damage, ship the drive back to the manufacturer for repairs. Unintended handling leads to secondary damages.

Keep magnetic memory cards or electronic devices out of the rotor's close-up range, because the alternating magnetic field can cause a delete of data. Be also careful with medical devices (e.g. pacemakers) which are sensitive to alternating magnetic fields.

The small gap between the stator and the magnets of the rotor function-bound has a thickness of only a few tenth of millimeter. Here, the danger of foreign objects accumulating in this gap exists but can be heard by scratching-sounds. In this case spinner should be removed and the motor should be blown-out with compressed air. Do not at all simply keep on using the drive. Be especially aware of cuttings which can almost irremovably stick to the magnets. In this case, the only thing that helps is a disassembly of the drive by the manufacturer.



## 7. Removal of motor

Removal of motor from sailplane is only allowed in case of **written permission** from manufacturer otherwise warranty is not valid anymore!

### Warning!

**It is not allowed to fly with removed motor from the sailplane, as C.G. position change significantly!**

**On back side of mounting wall are visible four M8 nuts, tightened over big spacer and rubber silen blocks. Please leave them at they are. Proper way of removing motor is to follow next steps:**

**To remove the motor assembly from the glider** (complete with spinner and propeller)

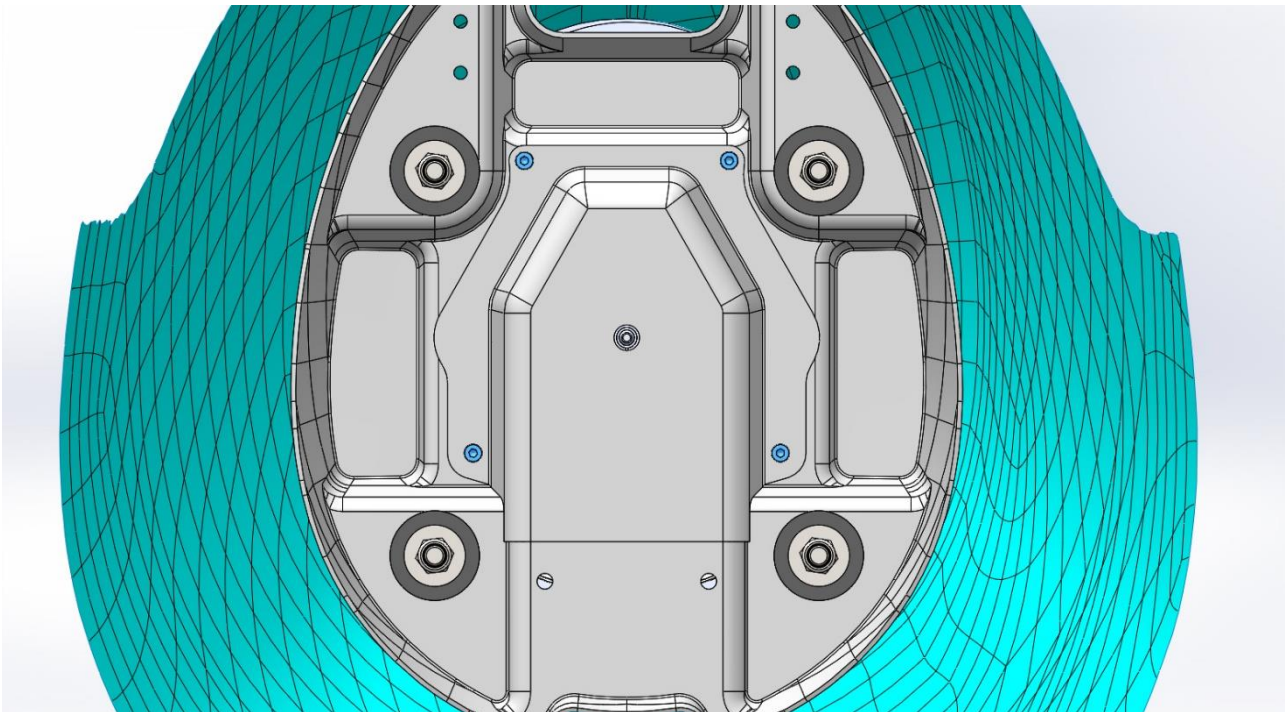

1. From the cockpit side, remove glass-fibre cover, mounted in the centre of the motor mounting rib. To accomplish this, remove four M4 bolts. Trough the centre of the cover goes pneumatic tube which is connected to pitot assembly. Carefully slide back cover in order not to damage pneumatic tube.

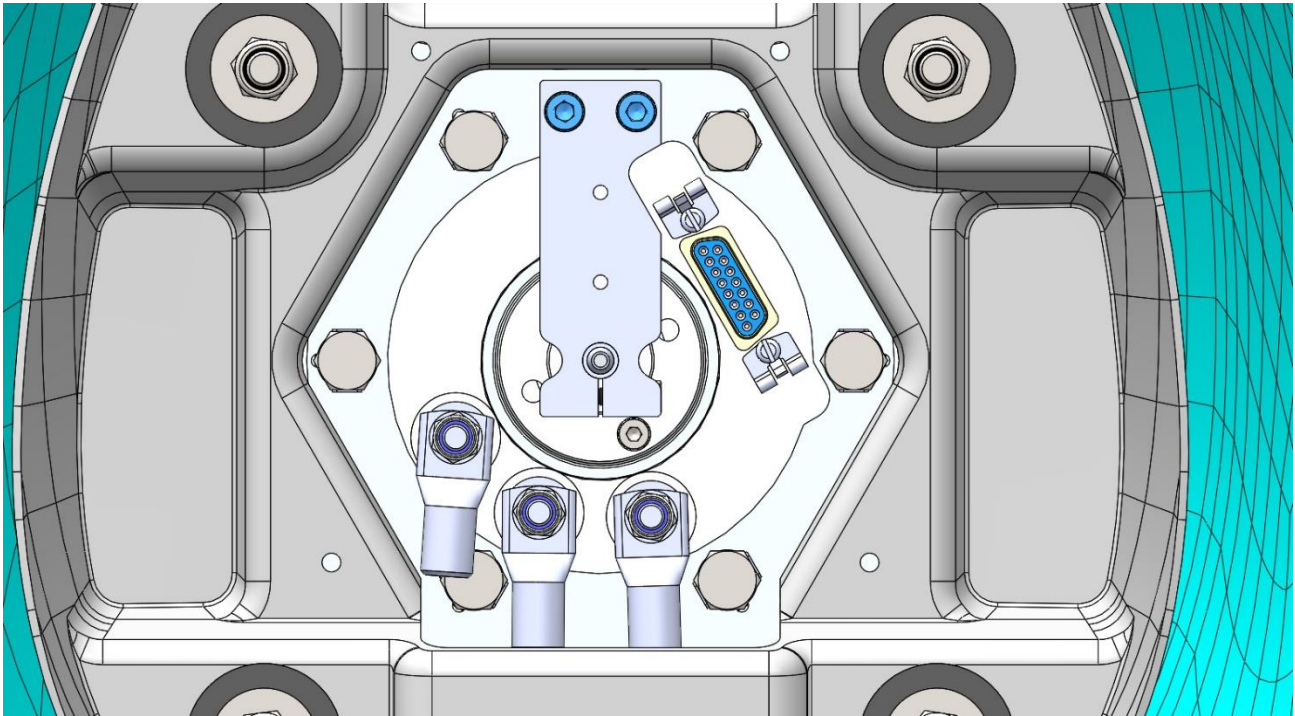

2. Remove pitot tube assembly which is fixed on the back side of motor mounting plate. To do that is necessary to unscrew two M5 bolts on top. Then carefully pull out pitot tube assembly.
3. Unlock two spring-locks which hold DB15 cable connector. Carefully unplug connector from the socket of motor rear wall.
4. Unscrew 3 locknuts from rear motor wall and disconnect 3 power cables. Each cable is marked with different colour of isolation over the cable shoe (red, blue and black). Take a photo so that you will know their proper order for assembly.
5. Un-secure six M8 bolts and unscrew them (note that M8 screw located below power cables has a lower head). To accomplish removal of the screws, support the motor assembly.
6. Take out motor assembly carefully. Note that centrifugal ventilator on the back side of the motor has bigger diameter than rotor rink. It is not possible to get motor out straight, as opening is not wide enough. It is necessary to rotate motor about 30 degrees to one side in order to get it out. Be careful not to damage spinner, or plastic covers below spinner.

## 8. Installation of motor

**To install motor back on glider**, follow the reverse order of previous chapter.

Take care about additional steps:

1. Below M8 motor fixation bolts, it is recommended to use new brass safety spacers
2. Make sure that power cables are connected in the same order as before (check your photo for reference). If order is not correct motor might not run at all, it might run but not achieving proper RPM or it might run in wrong direction. Use only new M6 all metal locknuts.
3. Make sure that there is at least 3mm of air gap distance between cable shoes and mounting wall and between cable shoes and M8 bolts. Lower left M8 bolt (below power cables) should have lower head.
4. Carefully plug in DB15 male connector into motor rear wall female connector. Secure connector on both sides with spring locks.

After motor is reinstalled, check that:

- Spinner is nicely located in the middle of the fuselage when spinner is in stop position. This means that surface of the spinner is as much as possible tangent to the fuselage contour in area of gap between spinner and fuselage.
- Gap between spinner and fuselage should be 1mm. Gap should be equal all around (on top should be the same as on bottom side, on left side should be equal as on right side).
- All bolted connections are assembled correctly and secured properly. Below six M8 bolts which hold motor in place are thin brass safety spacers, which ears needs to be bend 90 degrees against one of the 6 vertical surfaces of M8 hex head bolts.
- Start the motor on a ground and run it for a few seconds to check:
  - that motor rotating direction is counterclockwise (looking in front of the propeller), and that motor is running smoothly
  - that electronic braking of propeller works (above 1500 RPM)
  - FCU instrument is functioning properly (check about all functions of the FCU in its dedicated FCU manual)

---

**9. Repair and service**

In case of a fault or damage, please contact manufacturer.

**10. Revision history**

April 2019	Initial release of manual, v1.2
April 2020	Minor updates, v1.21